

(12) **EUROPEAN PATENT APPLICATION**  
published in accordance with Art. 158(3) EPC

(43) Date of publication:  
05.06.1996 Bulletin 1996/23

(51) Int. Cl.<sup>6</sup>: H04L 27/22

(21) Application number: 95922721.6

(86) International application number:  
PCT/JP95/01229

(22) Date of filing: 21.06.1995

(87) International publication number:  
WO 95/35615 (28.12.1995 Gazette 1995/55)

(84) Designated Contracting States:  
DE GB IT SE

- ADACHI, Fumiyuki  
Yokohama-shi, Kanagawa 236 (JP)
- OHNO, Koji  
Yokohama-shi, Kanagawa 235 (JP)
- SAWAHASHI, Mamoru  
Kanagawa 239 (JP)

(30) Priority: 22.06.1994 JP 140569/94

(71) Applicant: NTT MOBILE COMMUNICATIONS  
NETWORK INC.  
Minato-ku, Tokyo 105 (JP)

(74) Representative: Beresford, Keith Denis Lewis et al  
BERESFORD & Co.  
2-5 Warwick Court  
High Holborn  
London WC1R 5DJ (GB)

(72) Inventors:  
• HIGASHI, Akihiro  
Kanagawa 238-03 (JP)

(54) **SYNCHRONOUS DETECTOR AND SYNCHRONIZING METHOD FOR DIGITAL COMMUNICATION RECEIVER**

(57) A synchronous detecting method in which the transfer function of a propagation path is estimated by regarding the information symbols adjacent to pilot signals as known symbols and using the information symbols as pseudo-pilot signals. The method includes a step of estimating the transfer function by using the pilot signals, a step of performing interpolation synchronous detection of part of the information symbols by using the estimated transfer function, a step of storing the result of the interpolation synchronous detection as pseudo-pilot signals, a step of reestimating the transfer function

related to information symbols corresponding to the pseudo-pilot signals from the pseudo-pilot signals and the received signals corresponding to the pseudo-pilot signal, regarding the pseudo-pilots as known correct signals, and a step of performing interpolation synchronous detection of each information symbol by using the reestimated transfer function. Thus, the detection characteristic can be improved by estimating the transfer function with high accuracy even when the number of symbols per pilot signal is small.

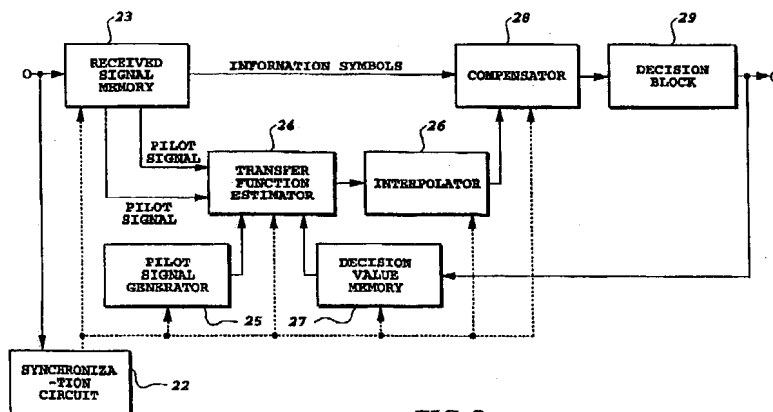

FIG. 3

## Description

## TECHNICAL FIELD

The present invention relates to a coherent detector and a coherent detection method for demodulating a signal in a receiver employed in digital mobile communications or the like.

## BACKGROUND ART

Various methods are employed for detecting digital signals in connection with modulation methods. Among these, a coherent detection method, which achieves detection using local oscillation in synchronism with a carrier frequency at a transmitting side, exhibits the best characteristics under Gaussian noise environment. In other words, the coherent detection method demands a minimum received-signal-power-to-noise ratio that fulfills a particular error rate. It is necessary, however, to fast estimate the transfer function of a propagation path at a receiving side to obtain the absolute phase of the transmission carrier required for the coherent detection. This is because the transfer function of the propagation path fluctuates sharply with time.

An interpolation coherent detection method is known as a method for carrying out the coherent detection by estimating the transfer function of the propagation path. For example, it is disclosed in Seiichi Sampei, "Fading Compensation for 16QAM in Land Communications", The Transactions of the Institute of Electronics, Information and Communication Engineers of Japan B-II, Vol. J72-B-II pp. 7-15, January 1989, or in its revised version, S. Sampei, et al. "Rayleigh Fading Compensation for QAM in Land Mobile Radio Communications", IEEE Transactions on Vehicular Technology, VOL. 42, No. 2, MAY 1993.

Fig. 1 illustrates a format of a signal used in such interpolation coherent detection. A transmitting side transmits a transmitted signal including a pilot signal P periodically inserted therein. The pilot signal has a pattern which is known both to transmitting and receiving sides, and contains one or more known symbols. One pilot signal P and an information symbol set (information signal) D sandwiched by successive two pilot signals P constitute one frame.

Fig. 2 shows a conventional receiver. Radio waves received by an antenna 1 are band-limited by a BPF (BandPass Filter) 2 to such an extent that an intended received signal suffer no distortion. The band-suppressed received signal is corrected to a normal level signal by an AGC (Automatic Gain Control) circuit 3, and the offset frequency between the carrier and a local oscillator is coarsely reduced by an AFC (Automatic Frequency Controller) 4. The BPF 2 is provided for ensuring the normal operation of the AGC 3 and the AFC 4.

Subsequently, the received signal undergoes quasi-coherent quadrature detection by a quasi-coherent quadrature detector 5 using a local signal from a local oscillator 6, which has the same frequency as the carrier of the received signal. The output of the quasi-coherent quadrature detector 5 is supplied to an interpolation compensator 9 through an LPF (LowPass Filter) 7 and an A/D converter 8. The LPF 7 is provided for suppressing noise from external bands and interference from adjacent channels. The interpolation compensator 9 estimates for each information symbol a transfer function by an interpolation method using the pilot signals, and compensates individual information symbols using the estimated transfer functions. The compensated signal undergoes decision by a decision block 10. Thus compensating each information symbol with the estimated transfer function enables the absolute phase detection. As a typical interpolation method, a first-order interpolation using two pilot signals, or a second-order interpolation using three pilot signals is generally used.

When the received signal includes noise, more accurate estimation of the transfer functions could be achieved by increasing the number of symbols per pilot signal, thereby reducing the estimation error of the transfer functions. Estimation of the transfer function associated with each information symbol can be carried out by applying the first-order or second-order Gaussian interpolation to the transfer functions estimated from the pilot signals.

In the conventional system described above, the transfer function associated with each information symbol can be estimated by a simple first-order interpolation when the fluctuations of the transfer functions of the propagation paths are much slower than the insertion period of the pilot signals. However, as the fluctuations of the transfer functions grow faster, the interpolation error increases, and hence, the insertion period of the pilot signal must be shortened. The shortening of the insertion period, however, increases the number of symbols of the pilot signals, and this will reduce the transmission efficiency. On the other hand, to shorten the insertion period while keeping the transmission efficiency constant, the number of symbols per pilot signal must be reduced, and this will increase the estimation error of the transfer functions.

Thus, the conventional interpolation coherent detection has a shortage in that the transmission efficiency must be reduced to cope with the fast changes in the transfer functions of the propagation paths.

## DISCLOSURE OF THE INVENTION

Therefore, an object of the present invention is to provide a coherent detector and a coherent detection method for a digital communication receiver, which can improve characteristics of absolute coherent detection by estimating the transfer function of the propagation path at high accuracy without increasing the number of symbols per pilot signals.

In a first aspect of the present invention, there is provided a coherent detector for a digital communication receiver, which performs coherent detection of a received signal including pilot signals of a known pattern and information signals, by estimating for individual information symbols of the information signals transfer functions of a propagation path of the received signal on the basis of the pilot signals, by correcting the information symbols with estimated transfer functions, and by deciding corrected information symbols, each of the pilot signals alternating with each one of the information signals at a fixed period, the coherent detector comprising:

- a received signal memory for storing the received signal;
- pilot signal generating means for generating the pilot signals of the known pattern;
- transfer function estimation means for estimating the transfer functions using the pilot signals stored in the received signal memory and the pilot signals of the known pattern supplied from the pilot signal generating means;
- interpolation means for interpolating a plurality of transfer functions estimated by the transfer function estimation means, thereby obtaining the transfer functions for the information symbols;
- compensation means for compensating information symbols stored in the received memory by using the transfer functions obtained by the interpolation means;
- decision means for deciding the information symbols compensated by the compensation means; and
- pseudo-pilot signal storing means for storing a predetermined number of information symbols which are outputted from the decision means and adjacent to the pilot signals as pseudo-pilot signals, wherein the transfer function estimation means reestimates for individual information symbols corresponding to the pseudo-pilot symbols the transfer functions of the propagation path by using the pseudo-pilot signals and the information symbols in the received signal memory which correspond to the pseudo-pilot signals.

The transfer function estimation means may further comprise:

- means for estimating a fading frequency from the pilot signals; and
- means for prestoring relationships between forgetting factors and estimation errors of the transfer functions with the fading frequency as a parameter, wherein one of the forgetting factors which will minimize the estimation errors is selected.

In a second aspect of the present invention, there is provided a coherent detection method for a digital communication receiver, which performs coherent detection of a received signal including pilot signals of a known pattern and information signals, by estimating for individual information symbols of the information signals transfer functions of a propagation path of the received signal on the basis of the pilot signals, by correcting the information symbols with estimated transfer functions, and by deciding corrected information symbols, each of the pilot signals alternating with each one of the information signals at a fixed period, the coherent detection method comprising the steps of:

- storing the received signal;
- generating the pilot signals of the known pattern;
- estimating the transfer functions using the pilot signals stored and the pilot signals of the known pattern;
- interpolating a plurality of transfer functions estimated, thereby obtaining the transfer functions for the information symbols;
- compensating information symbols by using the transfer functions obtained in the step of interpolating;
- deciding the information symbols compensated;
- storing a predetermined number of information symbols which are decided in the step of deciding and adjacent to the pilot signals as pseudo-pilot signals; and
- reestimating for individual information symbols corresponding to the pseudo-pilot symbols the transfer functions of the propagation path by using the pseudo-pilot signals and the information symbols in the received signal which correspond to the pseudo-pilot signals.

The coherent detection means for a digital communication receiver may further comprise the steps of:

- estimating a fading frequency from the pilot signals;
- prestoring relationships between forgetting factors and estimation errors of the transfer functions with the fading frequency as a parameter; and
- selecting one of the forgetting factors which will minimize the estimation errors.

In a third aspect of the present invention, there is provided a digital communication receiver including a coherent detector which performs coherent detection of a received signal including pilot signals of a known pattern and information signals, by estimating for individual information symbols of the information signals transfer functions of a propagation path of the received signal on the basis of the pilot signals, by correcting the information symbols with estimated transfer functions, and by deciding corrected information symbols, each of the pilot signals alternating with each one of the information signals at a fixed period, the coherent detector comprising:

a received signal memory for storing the received signal;  
 pilot signal generating means for generating the pilot signals of the known pattern;  
 transfer function estimation means for estimating the transfer functions using the pilot signals stored in the received  
 signal memory and the pilot signals of the known pattern supplied from the pilot signal generating means;  
 interpolation means for interpolating a plurality of transfer functions estimated by the transfer function estimation  
 means, thereby obtaining the transfer functions for the information symbols;  
 compensation means for compensating information symbols stored in the received memory by using the transfer  
 functions obtained by the interpolation means;  
 decision means for deciding the information symbols compensated by the compensation means; and  
 pseudo-pilot signal storing means for storing a predetermined number of information symbols which are outputted  
 from the decision means and adjacent to the pilot signals as pseudo-pilot signals,  
 wherein the transfer function estimation means reestimates for individual information symbols corresponding to  
 the pseudo-pilot symbols the transfer functions of the propagation path by using the pseudo-pilot signals and the infor-  
 mation symbols in the received signal memory which correspond to the pseudo-pilot signals.

The transfer function estimation means may further comprise:  
 means for estimating a fading frequency from the pilot signals; and  
 means for prestoring relationships between forgetting factors and estimation errors of the transfer functions with  
 the fading frequency as a parameter,  
 wherein one of the forgetting factors which will minimize the estimation errors is selected.

#### BRIEF DESCRIPTION OF THE DRAWINGS

Fig. 1 is a diagram illustrating a format of a signal employed in interpolation coherent detection;  
 Fig. 2 is a block diagram showing a configuration of a conventional receiver up to a detection stage;  
 Fig. 3 is a block diagram showing a first embodiment of a coherent detector in accordance with the present invention;  
 Fig. 4 is a diagram illustrating a format of a signal employed in the coherent detection of the present invention;  
 Fig. 5 is a graph illustrating average bit error rates of the present invention in comparison with those of a conventional  
 example;  
 Fig. 6 is a block diagram showing a second embodiment of a coherent detector in accordance with the present  
 invention; and  
 Fig. 7 is a graph showing variations in estimation errors due to forgetting factor.

#### BEST MODE FOR CARRYING OUT THE INVENTION

The invention will now be described with reference to the accompanying drawings.

#### EMBODIMENT 1

Fig. 3 is a block diagram showing a first embodiment of a coherent detector in accordance with the present invention.  
 The coherent detector corresponds to the combination of the interpolation compensator 9 and the decision block 10 of  
 the conventional receiver shown in Fig. 2.

The received signal undergone the quasi-coherent detection by the quasi-coherent quadrature detector 5 in Fig. 2  
 is passed through the LPF 7 and the A/D converter 8, and is fed to a synchronization circuit 22 and a received signal  
 memory 23 of the coherent detector of Fig. 3. The synchronization circuit 22 recovers clock timings of individual symbols,  
 and frame timings indicative of a repetitive interval of the pilot signals, thereby generating a symbol synchronizing signal  
 and a frame synchronizing signal. The symbol synchronizing signal and the frame synchronizing signal are fed to various  
 blocks of the coherent detector as indicated by broken lines in Fig. 3.

The received signal memory 23 has a memory capacity equal to or greater than the total number of symbols in two  
 pilot signals and the information symbol set therebetween, and stores baseband digital data fed from the A/D converter  
 8. The received signal memory 23 reads out two successive pilot signals by using the frame synchronizing signal, and  
 fed the pilot signals to a transfer function estimator 24.

The transfer function estimator 24 estimates the transfer function of a propagation path by carrying out operation  
 between a reference pilot signal of a known pattern which is fed from a pilot signal generator 25 and the pilot signals  
 contained in the received signal. The transfer function of the propagation path can be estimated on the real time basis  
 by iterating the operation each time the pilot symbol is received. One of features of the present invention exists in the  
 estimation method of the transfer function, but its detail will be described later. The estimated transfer function is fed to  
 an interpolator 26.

The interpolator 26 carries out a first-order or second-order interpolation using the estimated successive transfer functions, and estimates a transfer function at each information symbol timing between the pilot signals. Thus, the interpolator 26 generates one estimated transfer function per information symbol, and feeds it to a compensator 28.

The compensator 28 compensates individual information symbols using the estimated transfer functions. The compensated information symbols are fed to a decision block 29. The decision block 29 performs absolute coherent detection of individual information symbols, and produces its results. Part of the decision results are stored in a decision value memory 27. For example, when a symbol set  $D_1$  as shown in Fig. 4 is obtained as the decision results, the decision value memory 27 stores an information symbol set  $A_1$  consisting of  $L_q$  symbols adjacent to a pilot signal  $P_1$ , and an information symbol set  $B_1$  consisting of  $L_q$  symbols adjacent to a pilot signal  $P_2$ . With other information symbol sets  $D_k$ , the decision value memory 27 stores an information symbol set  $A_k$  consisting of  $L_q$  symbols adjacent to a pilot signal  $P_k$ , and an information symbol set  $B_k$  consisting of  $L_q$  symbols adjacent to a pilot signal  $P_{k+1}$ . These information symbol sets  $A_k$  and  $B_k$ , each consisting of a predetermined number of symbols, are used to estimate (reestimate) the transfer functions.

More specifically, the transfer function estimator 24 estimates the transfer functions associated with the information symbol sets  $A_k$  and  $B_k$  under the assumption that the information symbol sets  $A_k$  and  $B_k$  (each including  $L_q$  symbols) fed from the decision value memory 27 as new pilot signals with a known pattern (referred to as pseudo-pilot signals below). In other words, the transfer function estimator 24 estimates transfer functions associated with individual symbols in the information symbol sets  $A_k$  and  $B_k$ , considering that the pseudo-pilot signals fed from the decision value memory 27 as true pilot signals. The estimation of the transfer functions is carried out in the following procedure in a manner similar to that of the true pilot signals  $P_k$ . First, assuming that individual symbols of the pseudo-pilot signal are designated by  $u(n)$  ( $n = 1, 2, \dots, L_q$ ), individual symbols of the received signal are represented by  $r(n)$ , and estimated values of the transfer functions associated with the individual symbols are denoted by  $Z'(n)$ ,  $Z'(n)$  is obtained by solving the following equation.

$$\Phi(n)Z'(n) = \Theta(n) \quad (1)$$

where  $\Phi(n)$  is an autocorrelation of each pseudo-pilot symbol constituting the pseudo-pilot signal, and  $\Theta(n)$  is a cross-correlation between a pseudo-pilot symbol  $u(n)$  and a received signal symbol  $r(n)$ . These are given by the following expressions.

$$\Phi(n) = \lambda\Phi(n-1) + u(n)u^*(n) \quad (2)$$

$$\Theta(n) = \lambda\Phi(n-1)Z'(n-1) + u(n)r^*(n) \quad (3)$$

where  $\lambda$  is a forgetting factor which provides individual symbols with weighting factors varying exponentially. The forgetting factor is a coefficient that improves tracking ability by reducing the effect of the past. For example, weighting factors are gradually reduced as they go back to the past in such a fashion that the first preceding symbol is multiplied by  $\lambda$  ( $\leq 1.0$ ), and the second preceding symbol is multiplied by  $\lambda$ . From equations (1) - (3), the estimated values  $Z'(n)$  of the transfer functions are given by the following equation.

$$Z'(n) = \{\lambda\Phi(n-1)Z'(n-1) + u(n)r^*(n)\} / \{\lambda\Phi(n-1) + u(n)r^*(n)\} \quad (4)$$

Calculating equation (4) sequentially for individual symbols of the information symbol sets  $A_k$  and  $B_k$ , the estimated transfer functions associated with respective symbols can be obtained. Although a method for estimating the transfer functions associated with the pseudo-pilot symbols is explained here, the transfer functions associated with the pilot signals are estimated in a similar manner. The estimation method itself is known, and is disclosed in Simon Haykin, "Adaptive Filter Theory", Prentice Hall, pp. 381-385, or the foregoing Sampei, et al. paper.

The present invention is characterized in that a predetermined number of information symbols adjacent to the pilot signals are used as pseudo-pilot signals, and the transfer function is estimated for each of those information symbols.

The estimated transfer functions are fed to the interpolator 26. The interpolator 26 obtains transfer functions associated with individual symbols in the information symbol set  $D_1$  by the following equation using Gaussian interpolation.

$$Z'_{k+m/L_d} = \{1 - (m/L_d)\}Z'_k + (m/L_d)Z'_{k+1} \quad (5)$$

where  $Z'_k$  and  $Z'_{k+1}$  are estimated values of the transfer functions obtained from the  $k$ -th and  $k+1$ -th pilot signals and pseudo-pilot signals, respectively, and  $Z'_{k+m/L_d}$  is an estimated value of the transfer function associated with the  $m$ -th information symbol in the  $L_d$  information symbols between the pilot signals.

Since the present invention thus compensates the variations of the transfer functions, it can achieve the absolute phase detection.

Furthermore, since the present invention handles the signal after the quasi-coherent detection as a digital signal, blocks of Fig. 3 can be implemented by a digital circuit, or a microprocessor such as a digital signal processor. Moreover, signal delays by the processing can be minimized by fast performing the estimation and interpolation of the transfer functions, and compensation and decision of the symbols.

Fig. 5 is a graph illustrating average bit error rates when the coherent detector in accordance with the present invention is employed, in comparison with those when a conventional apparatus is used. The abscissas represent the number of symbols per pilot signal, and the ordinates indicate the average bit error rates. In this case, it is assumed that  $E_b/N_0$  (Energy per bit to Noise spectral density) is 6 dB, and that there are no fluctuations in the propagation path. Accordingly, the insertion period of the pilot signals has no effect on the bit error rate.

In Fig. 5, the broken line indicates a theoretical limit, open squares represent results of a conventional interpolation coherent detection using only the pilot signals, and solid squares represent results of the interpolation coherent detection in accordance with the present invention using part of the information symbols as the pseudo-pilot signals. The number of the information symbols used as the pseudo-pilot signal is  $L_q = 10$ .

As is seen from the graph, using the pseudo-pilot signals makes it possible to reduce the number of symbols per pilot signal to less than half of that of the conventional apparatus. If the transmission efficiency is kept constant, the pilot signals can be inserted at every 1/2 interval when the number of symbols per pilot signal is 1/2. Accordingly, even if the transfer function of the propagation path varies at a double rate, the coherent detector can follow the variation. Thus, the present invention is particularly effective to deal with fast variations in the transfer functions of the propagation paths by inserting the pilot signals with a small number of symbols at a short period.

## EMBODIMENT 2

Fig. 6 is a block diagram showing a major portion of a second embodiment of a coherent detector in accordance with the present invention. This embodiment is characterized in that it automatically changes the forgetting factor  $\lambda$  of the foregoing equations (2) and (3) in response to the fading frequency.

Fig. 7 is a graph illustrating forgetting factor versus estimation error of the transfer function with  $f_D T$  as a parameter. The  $f_D T$  is a product of the maximum Doppler frequency  $f_D$  (Hz) and one symbol length  $T$  (second), and corresponds to the fading frequency normalized by one symbol length. As is seen from Fig. 7, the forgetting factors minimizing the estimation error vary as  $f_D T$  varies. For example, the forgetting factors must be set smaller as fading grow faster, that is, as  $f_D T$  becomes larger. The following methods can be employed for setting the forgetting factors.

### (1) A method of using a fixed forgetting factor.

It is an important issue at which value the forgetting factor should be fixed when a fixed value is used. One method is to set it at such a value that can respond to the maximum Doppler frequency  $f_D$ , and another is to set at such a value that corresponds to an average  $f_D T$ . As is seen from Fig. 7, a value about 0.85 is optimum in the former case, and a value about 0.91 is optimum in the latter case.

### (2) A method of switching the forgetting factors in accordance with the fading frequency.

The second embodiment adopts this method, which will now be described with reference to Fig. 6.

The present embodiment differs from the first embodiment in the arrangement of the transfer function estimator 24: The transfer function estimator of the second embodiment differs in the following from that of the first embodiment shown in Fig. 3.

(1) A block having a function similar to that of the transfer function estimator 24 in Fig. 3 is denoted as a transfer function calculator 24a in Fig. 6.

(2) A fading frequency estimator 24b is provided.

The fading frequency estimator 24b estimates the phase difference between the pilot signals at both ends of an information signal, and estimates the fading frequency from the estimated phase difference.

(3) A forgetting factor versus estimation error memory 24c is provided for storing data corresponding to these in the graph of the forgetting factor versus estimation error as illustrated in Fig. 7.

The memory 24c is fed with a fading frequency estimated by the fading frequency estimator 24b, so that the forgetting factors that will minimize the estimation errors are obtained. The transfer function calculator 24a estimates the transfer functions by substituting the forgetting factors into equations (2) - (4).

The second embodiment make it possible to estimate the optimum transfer functions in response to the moving speed of a mobile station.

## Claims

1. A coherent detector for a digital communication receiver, which performs coherent detection of a received signal including pilot signals of a known pattern and information signals, by estimating for individual information symbols of said information signals transfer functions of a propagation path of said received signal on the basis of said pilot signals, by correcting said information symbols with estimated transfer functions, and by deciding corrected information symbols, each of said pilot signals alternating with each one of said information signals at a fixed period, said coherent detector characterized by comprising:
- a received signal memory for storing said received signal;
  - pilot signal generating means for generating said pilot signals of said known pattern;
  - transfer function estimation means for estimating said transfer functions using said pilot signals stored in said received signal memory and said pilot signals of said known pattern supplied from said pilot signal generating means;
  - interpolation means for interpolating a plurality of transfer functions estimated by said transfer function estimation means, thereby obtaining said transfer functions for said information symbols;
  - compensation means for compensating information symbols stored in said received memory by using said transfer functions obtained by said interpolation means;
  - decision means for deciding said information symbols compensated by said compensation means; and
  - pseudo-pilot signal storing means for storing a predetermined number of information symbols which are outputted from said decision means and adjacent to said pilot signals as pseudo-pilot signals,
- wherein said transfer function estimation means reestimates for individual information symbols corresponding to said pseudo-pilot symbols said transfer functions of said propagation path by using said pseudo-pilot signals and said information symbols in said received signal memory which correspond to said pseudo-pilot signals.
2. The coherent detector for a digital communication receiver as claimed in claim 1, characterized in that said transfer function estimation means further comprises:
- means for estimating a fading frequency from said pilot signals; and
  - means for prestoring relationships between forgetting factors and estimation errors of said transfer functions with said fading frequency as a parameter,
- wherein one of said forgetting factors which will minimize said estimation errors is selected.
3. A coherent detection method for a digital communication receiver, which performs coherent detection of a received signal including pilot signals of a known pattern and information signals, by estimating for individual information symbols of said information signals transfer functions of a propagation path of said received signal on the basis of said pilot signals, by correcting said information symbols with estimated transfer functions, and by deciding corrected information symbols, each of said pilot signals alternating with each one of said information signals at a fixed period, said coherent detection method characterized by comprising the steps of:
- storing said received signal;
  - generating said pilot signals of said known pattern;
  - estimating said transfer functions using said pilot signals stored and said pilot signals of said known pattern;
  - interpolating a plurality of transfer functions estimated, thereby obtaining said transfer functions for said information symbols;
  - compensating information symbols by using said transfer functions obtained in said step of interpolating;
  - deciding said information symbols compensated;
  - storing a predetermined number of information symbols which are decided in said step of deciding and adjacent to said pilot signals as pseudo-pilot signals; and
  - reestimating for individual information symbols corresponding to said pseudo-pilot symbols said transfer functions of said propagation path by using said pseudo-pilot signals and said information symbols in said received signal which correspond to said pseudo-pilot signals.
4. The coherent detection means for a digital communication receiver as claimed in claim 3, further characterized by comprising the steps of:
- estimating a fading frequency from said pilot signals;
  - prestoring relationships between forgetting factors and estimation errors of said transfer functions with said fading frequency as a parameter; and
  - selecting one of said forgetting factors which will minimize said estimation errors.
5. A digital communication receiver including a coherent detector which performs coherent detection of a received signal including pilot signals of a known pattern and information signals, by estimating for individual information

symbols of said information signals transfer functions of a propagation path of said received signal on the basis of said pilot signals, by correcting said information symbols with estimated transfer functions, and by deciding corrected information symbols, each of said pilot signals alternating with each one of said information signals at a fixed period, said coherent detector characterized by comprising:

a received signal memory for storing said received signal;

pilot signal generating means for generating said pilot signals of said known pattern;

transfer function estimation means for estimating said transfer functions using said pilot signals stored in said received signal memory and said pilot signals of said known pattern supplied from said pilot signal generating means;

interpolation means for interpolating a plurality of transfer functions estimated by said transfer function estimation means, thereby obtaining said transfer functions for said information symbols;

compensation means for compensating information symbols stored in said received memory by using said transfer functions obtained by said interpolation means;

decision means for deciding said information symbols compensated by said compensation means; and

pseudo-pilot signal storing means for storing a predetermined number of information symbols which are outputted from said decision means and adjacent to said pilot signals as pseudo-pilot signals,

wherein said transfer function estimation means reestimates for individual information symbols corresponding to said pseudo-pilot symbols said transfer functions of said propagation path by using said pseudo-pilot signals and said information symbols in said received signal memory which correspond to said pseudo-pilot signals.

6. The digital communication receiver as claimed in claim 5, characterized in that said transfer function estimation means further comprises:

means for estimating a fading frequency from said pilot signals; and

means for prestoring relationships between forgetting factors and estimation errors of said transfer functions with said fading frequency as a parameter,

wherein one of said forgetting factors which will minimize said estimation errors is selected.



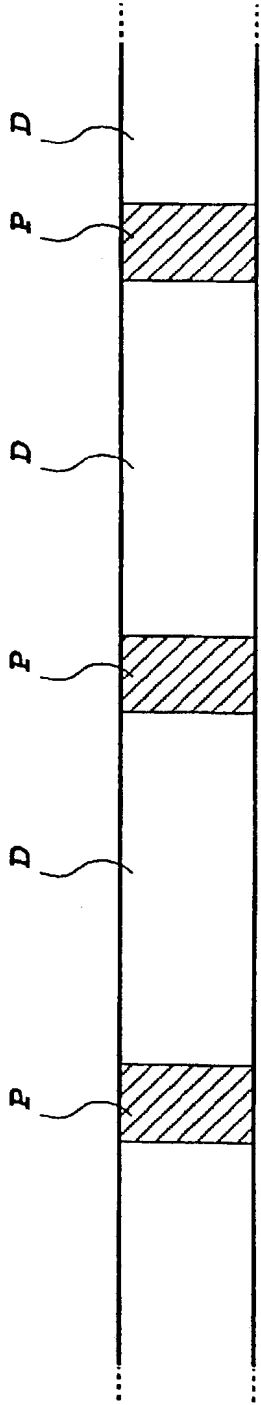

**FIG.1**  
*(PRIOR ART)*

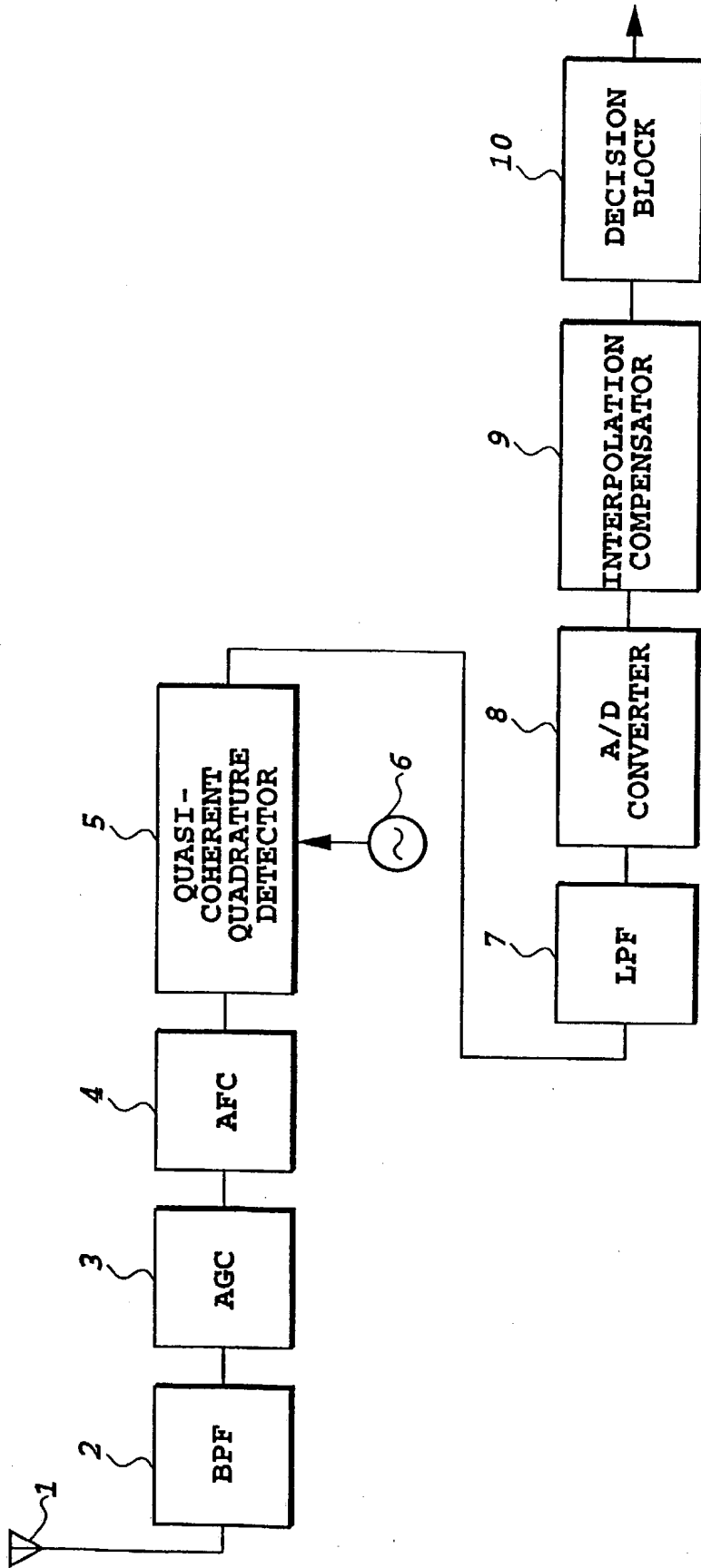

**FIG. 2**  
*(PRIOR ART)*

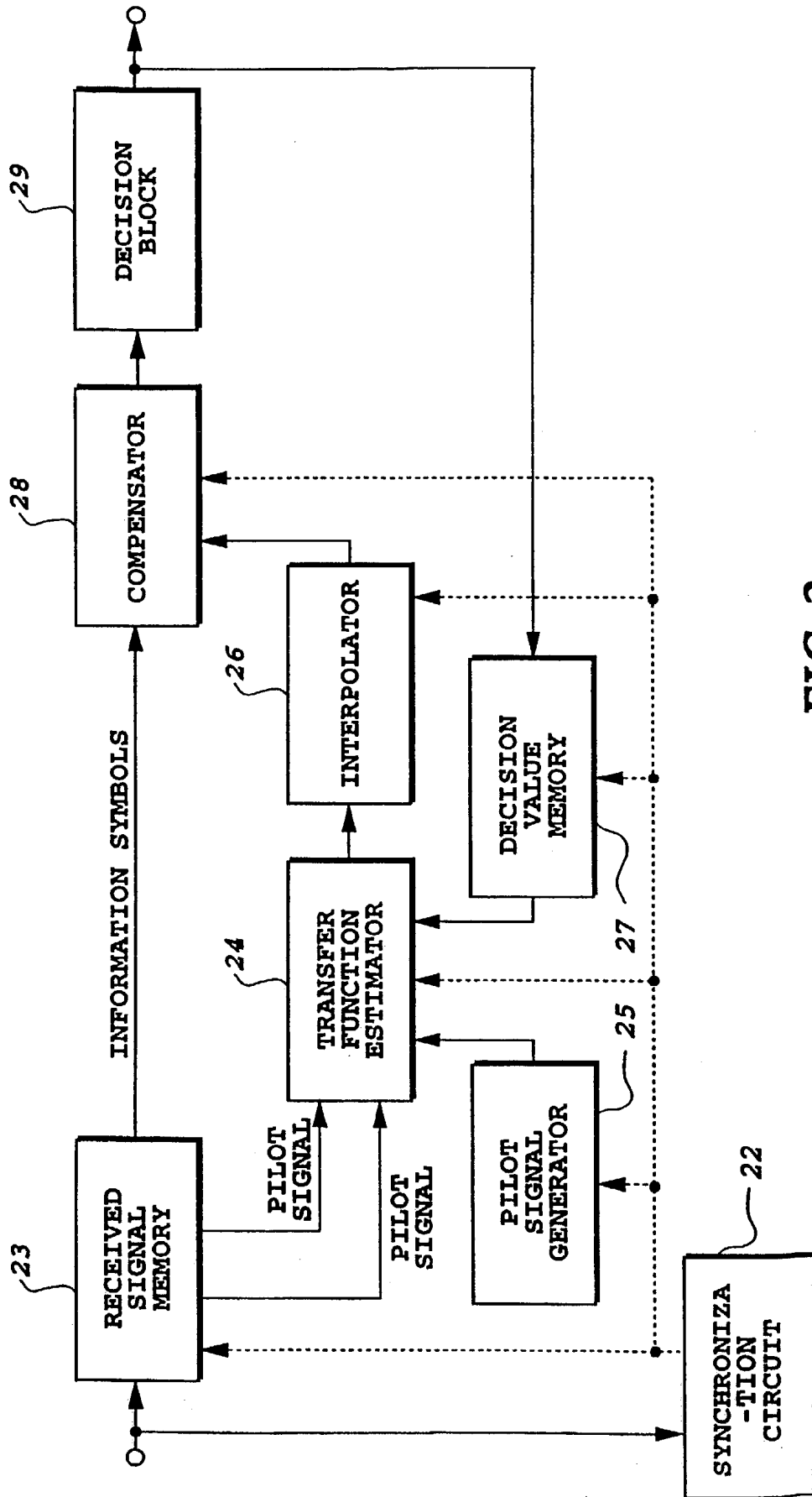

FIG. 3

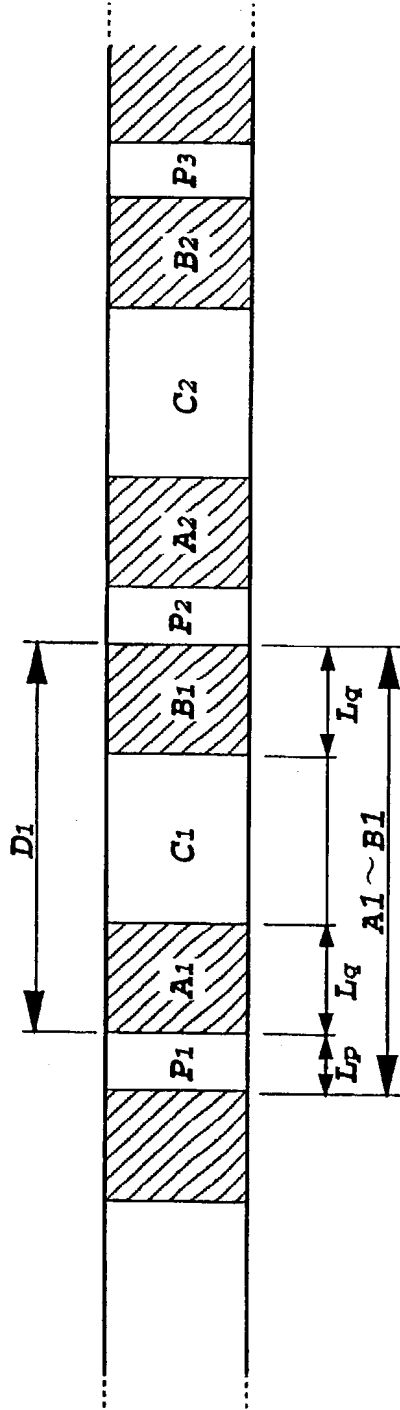
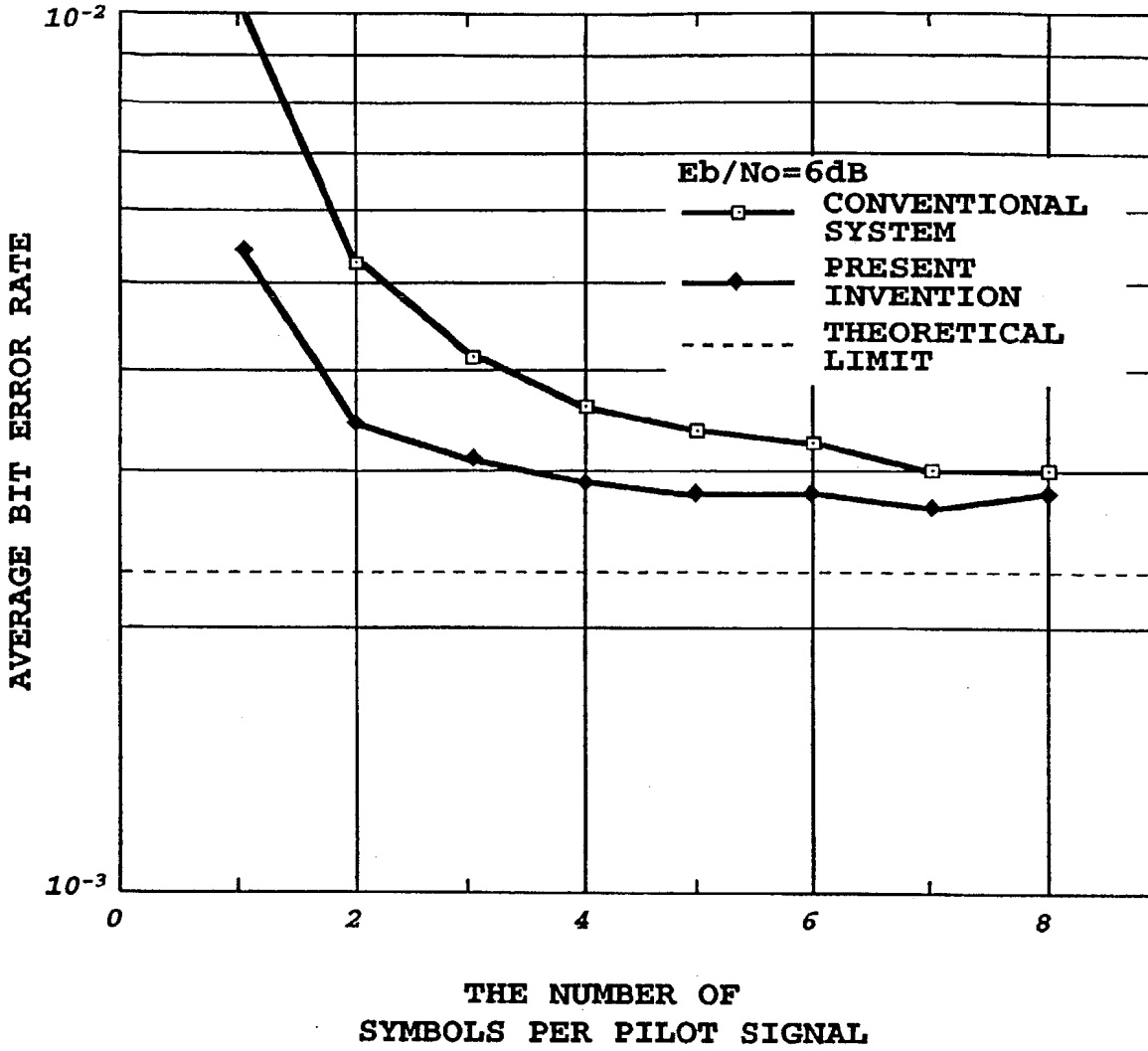

FIG.4



**FIG.5**

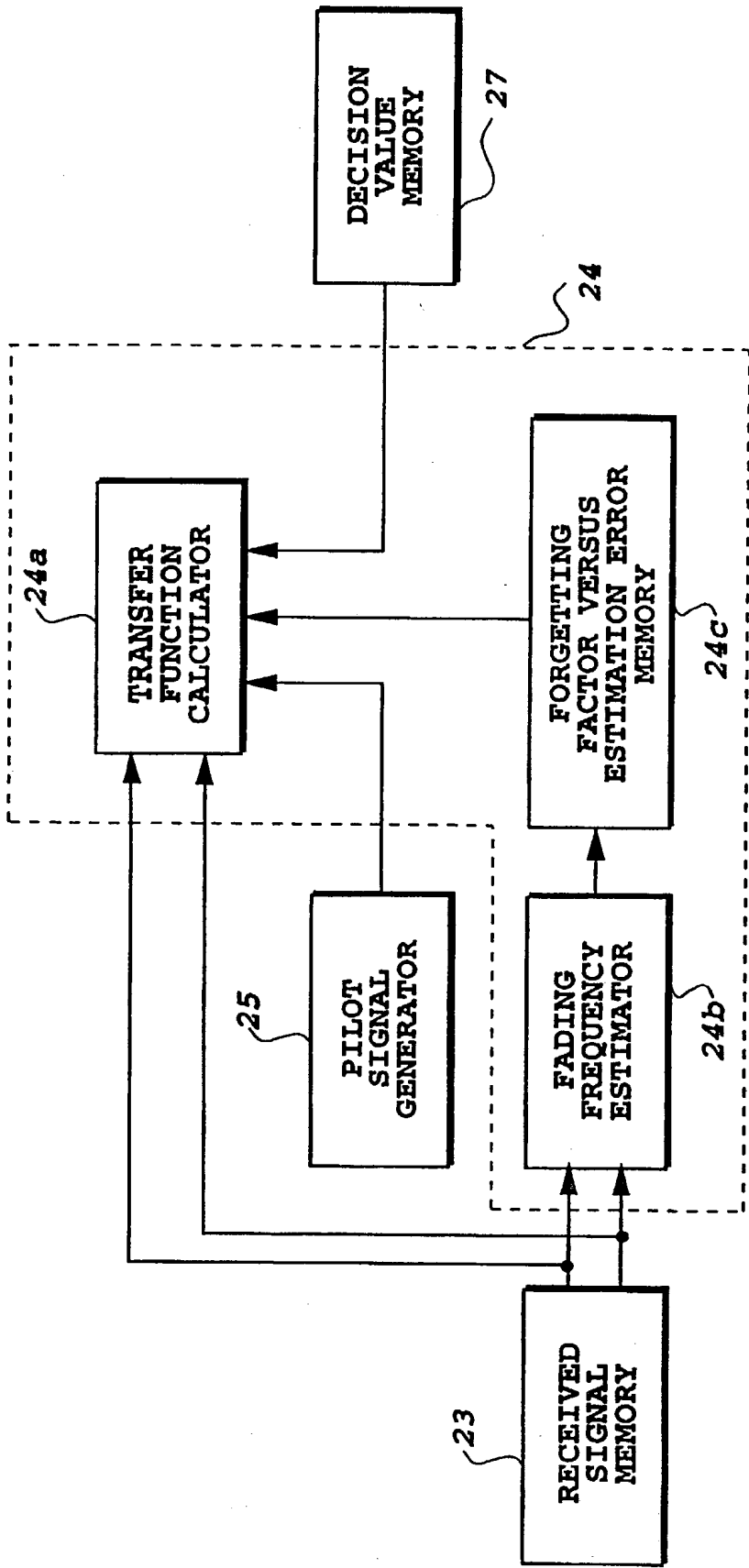

FIG. 6

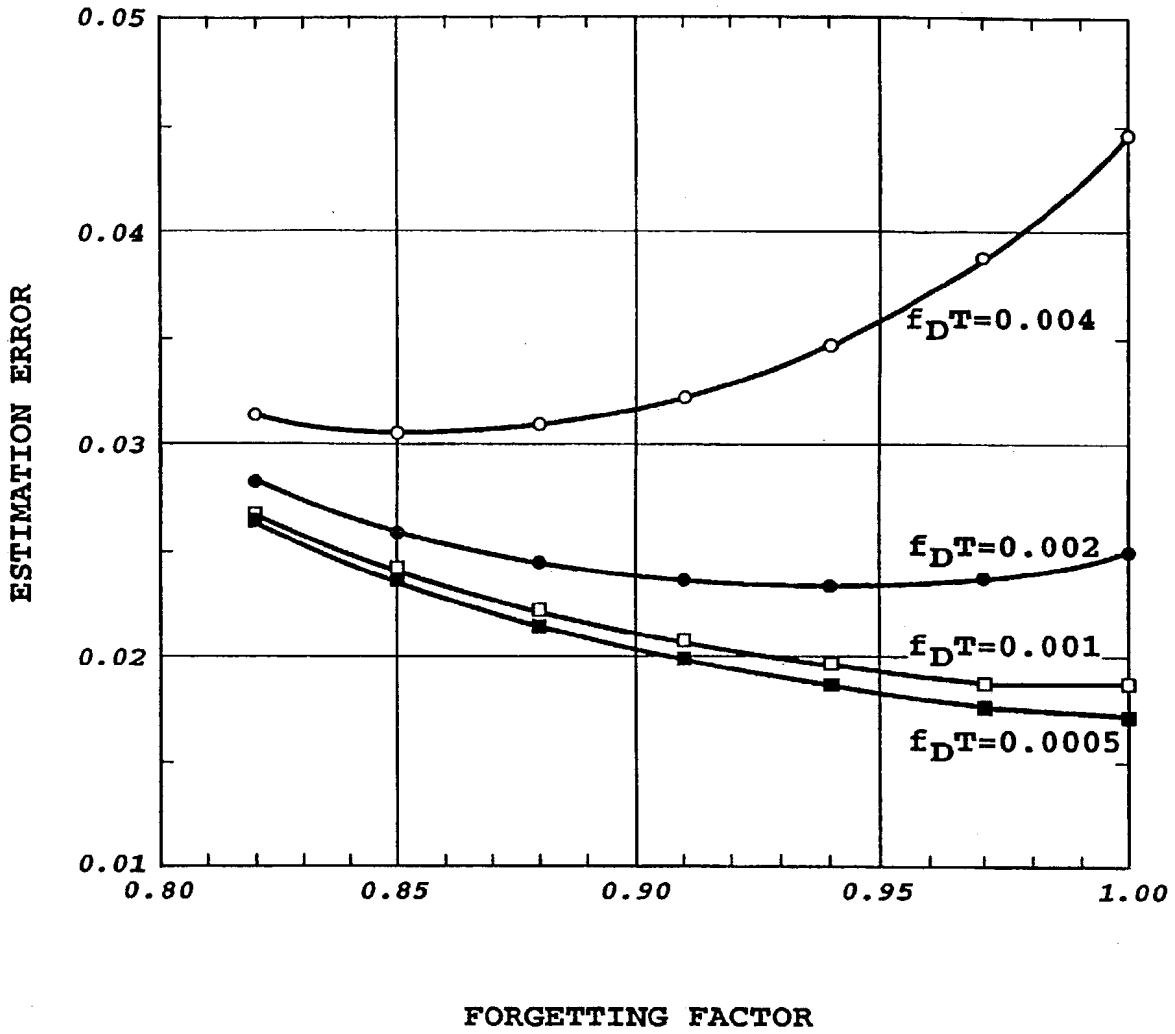

FIG. 7

## INTERNATIONAL SEARCH REPORT

International application No.

PCT/JP95/01229

<b>A. CLASSIFICATION OF SUBJECT MATTER</b>		
Int. Cl <sup>6</sup> H04L27/22		
According to International Patent Classification (IPC) or to both national classification and IPC		
<b>B. FIELDS SEARCHED</b>		
Minimum documentation searched (classification system followed by classification symbols)		
Int. Cl <sup>6</sup> H04L27/00-27/38		
Documentation searched other than minimum documentation to the extent that such documents are included in the fields searched		
Jitsuyo Shinan Koho 1971 - 1995		
Kokai Jitsuyo Shinan Koho 1971 - 1995		
Electronic data base consulted during the international search (name of data base and, where practicable, search terms used)		
<b>C. DOCUMENTS CONSIDERED TO BE RELEVANT</b>		
Category*	Citation of document, with indication, where appropriate, of the relevant passages	Relevant to claim No.
P, Y	JP, 7-46284, A (Mitsubishi Electric Corp.), February 14, 1995 (14. 02. 95) (Family: none)	
P, A	Line 30, right column, page 4 to line 17, left column, page 6, Fig. 1	1, 3, 5 2, 4, 6
P, Y	IEICE Technical Research Report Vol. 94, No. 312, October 28, 1994 (Tokyo), Akihiro Higashi, Tsutomu Taguchi, Koji Ono	
P, A	"Characteristics of an Interpolation Type Synchronous Detector RAKE in DC/CDMA p. 57-62	1, 3, 5 2, 4, 6
A	Seasonal Report of Communication Synthesis Institute, Vol. 37, No. 1, February, 1991 (Tokyo), Masaichi Mihei "System for Compensating Fading Distortion in Multivalue QAM", p. 87-98	1 - 6
<input checked="" type="checkbox"/> Further documents are listed in the continuation of Box C. <input type="checkbox"/> See patent family annex.		
* Special categories of cited documents:		
"A"	document defining the general state of the art which is not considered to be of particular relevance	"T" later document published after the international filing date or priority date and not in conflict with the application but cited to understand the principle or theory underlying the invention
"E"	earlier document but published on or after the international filing date	"X" document of particular relevance; the claimed invention cannot be considered novel or cannot be considered to involve an inventive step when the document is taken alone
"L"	document which may throw doubts on priority claim(s) or which is cited to establish the publication date of another citation or other special reason (as specified)	"Y" document of particular relevance; the claimed invention cannot be considered to involve an inventive step when the document is combined with one or more other such documents, such combination being obvious to a person skilled in the art
"O"	document referring to an oral disclosure, use, exhibition or other means	"Z" document member of the same patent family
"P"	document published prior to the international filing date but later than the priority date claimed	
Date of the actual completion of the international search	Date of mailing of the international search report	
August 28, 1995 (28. 08. 95)	September 19, 1995 (19. 09. 95)	
Name and mailing address of the ISA/ Japanese Patent Office	Authorized officer	
Facsimile No.	Telephone No.	